

**TEST REPORT**

Rendered to:

**FAIRWAY BUILDING PRODUCTS, LP**

For:

***Solutions Railing Systems***

**3-1/2 in Flange Mounting Post**

**Report No: A3925.02-119-19**

**Test Date: 02/23/11**

**Report Date: 03/15/11**

**TEST REPORT**

A3925.02-119-19  
March 15, 2011

---

**TABLE OF CONTENTS**

1.0 General Information.....	1
1.1 Product.....	1
1.2 Project Description .....	1
1.3 Limitations.....	1
1.4 Product Description .....	2
2.0 Structural Performance Testing .....	2
2.1 Scope.....	2
2.2 Test Load and Deflection Criteria .....	2
2.3 Test Equipment.....	2
2.4 Test Setup .....	3
2.5 Test Procedure .....	3
2.6 Test Results.....	3
2.7 Summary and Conclusions .....	6
3.0 Closing Statement .....	7
Revision Log.....	8
Appendix A - Drawings	
Appendix B - Photographs	

## **TEST REPORT**

Rendered to:

FAIRWAY BUILDING PRODUCTS, LP  
P.O. Box 37  
53 Eby Chiques Road  
Mount Joy, Pennsylvania 17552

Report No.: A3925.02-119-19  
Test Date: 02/23/11  
Report Date: 03/15/11

### **1.0 General Information**

#### **1.1 Product**

*Solutions* Railing Systems –3-1/2 in Flange Mounting Post

#### **1.2 Project Description**

Architectural Testing was contracted by the manufacturer to conduct structural performance tests on the *Solutions* Railing System's redesigned 3-1/2 in flange mounting post. This report is reissued in the name of Fairway Building Products, LP through the written authorization of the manufacturer. The post was evaluated in accordance with the following ASTM standards:

ASTM E 935-00 (Reapproved 2006), *Standard Test Methods for Performance of Permanent Metal Railing Systems and Rails for Buildings*

ASTM E 985-00 (Reapproved 2006), *Standard Specification for Permanent Metal Railing Systems and Rails for Buildings*

#### **1.3 Limitations**

All tests performed were to evaluate structural performance of the aluminum post to carry and transfer imposed loads to the supporting structure. The test specimens evaluated included the stand alone post only. Anchorage of support posts to the supporting structure was not included in the scope of this testing and would need to be evaluated separately.

## 1.4 Product Description

The manufacturer provided the post test specimens with the following details:

3-1/2 in square by 45 in long by 0.075 wall 6063-T5 aluminum extrusion,  
filet welded to a 5-7/16 in square by 0.30 in thick 6005-T5 aluminum plate,  
with a 0.42 in by 0.55 in slotted hole in each corner (for anchors)

See drawings in Appendix A and photographs in Appendix B for additional details.

## 2.0 Structural Performance Testing

### 2.1 Scope

Three post specimens were tested according to Test Method A described in ASTM E 935 in a laboratory set to maintain temperature in the range of  $68 \pm 4^\circ\text{F}$  and humidity in the range of  $50 \pm 5\%$  RH.

### 2.2 Test Load and Deflection Criteria

The test load criteria for railing support posts are defined in ASTM E 985, Section 7.1 as:

1. 365 lb concentrated horizontal load;
2. 60 plf uniformly distributed horizontal load.

These loads from Subsection 7.1.5 represent the worse case end-use and occupancy category loading defined in ASTM E 985. For a post supporting rail lengths greater than 6.08 feet, the 60 plf load is worse case than the 365 lb load.

The deflection criteria for railing support posts are defined in ASTM E 985, Section 7.2 as:

1. maximum deflection at maximum test load  $\leq (\text{rail height}) / 12$   
= 3.50 in for a 42 in supported rail height;
2. maximum residual deflection  $\leq 20\% \times (\text{rail height}) / 12$   
= 0.70 in for a 42 in rail height;
3. maximum residual deflection  $\leq 1/2$  in.

### 2.3 Test Equipment

The posts were mounted to a steel channel using Grade 8, 3/8 in hardware to simulate anchorage to concrete. The post assembly was then tested on a self-contained rigid steel test fixture designed to accommodate anchorage of the post assembly and application of the required test loads. The specimens were loaded using an electric winch mounted to a rigid steel test frame. High strength steel cables and a 3 in wide nylon lifting strap were used to impose test loads on the specimens. Applied load was measured using an electronic load cell located in-line with the loading system. An electronic linear displacement transducer, mounted to an independent reference frame, was used to measure deflection. Deflections and load values were electronically recorded continuously throughout the loading process.

## 2.4 Test Setup

Each support post specimen was tested in a "stand-alone" configuration which is considered a worse-case configuration than with rails attached to it as specified in the referenced standards. Each test specimen was inspected prior to testing to verify size and general condition of the materials, assembly and installation. No potentially compromising defects were observed prior to testing. See photographs in Appendix B for individual test setups.

## 2.5 Test Procedure

Test procedures were conducted according to the referenced standards and are further defined below.

### Method A - *Application of Horizontal Static Load to Post at Top Rail Height*

- A preload of 50% of test load was applied and then released
- A load of 25% of test load was applied and deflection readings were zeroed
- Load was increased to 40% of test load and maintained for at least 2 minutes
- Load was increased to 55% of test load and maintained for at least 2 minutes
- Load was increased to 70% of test load and maintained for at least 2 minutes
- Load was increased to 85% of test load and maintained for at least 2 minutes
- Load was increased to the full test load and maintained for at least 2 minutes
- Load was decreased to 25% of test load and deflections recorded
- Deflections were also recorded at the conclusion of each 2 minute hold period

## 2.6 Test Results

The following tests were performed February 23, 2011 on three test specimens in accordance with the test load requirements of the referenced standards.

### Key to Test Results Tables:

Load Level: Target test load expressed as percent of test load criterion and (lb)

Applied Load: Actual applied load - Where more than one value is reported, the applied load was the range (min. - max.) that was held during the time indicated for the test.

Elapsed Time (E.T.): The length of time into the test with zero established at the beginning of the loading procedure - Where more than one value is reported, the time was the range (start-end) that the applied load was maintained.

Displacement: Total specimen displacement at 42 in above the post mounting surface

2.6 Test Results (Continued)

Test Specimen 1 of 3

Test Method A			
60 plf x 7 ft - 3-1/2 in = 438 lb Horizontal Concentrated Load on Post At Top Rail Height			
Load Level	Applied Load (lb)	E.T. (min:sec)	Displacement at 42 in Height (in)
0% (0 lb)	0	00:00	-----
50% (219 lb)	220	00:30	-----
25% (110 lb)	110	01:21	0.00
40% (175 lb)	175 – 177	01:59 – 04:05	0.17
55% (241 lb)	241 – 243	04:23 – 06:24	0.37
70% (307 lb)	307 – 310	06:46 – 08:51	0.61
85% (372 lb)	372 – 375	09:12 – 11:34	0.95
100% (438 lb)	437 - 443	11:51 – 13:57	<b>1.44</b>
25% (110 lb)	110	15:47	<b>0.60</b>
<p><u>Deflection Criteria per Section 7.2 of ASTM E 985:</u></p> <p>Maximum Allowable Deflection at Test Load: <math>\frac{h}{12} = \frac{42}{12} = 3.50\text{ in} &gt; 1.44\text{ in} \therefore \text{ok}</math></p> <p>Maximum Allowable Residual Deflection at 25% Load:</p> $20\% \times \left(\frac{h}{12}\right) = 0.2 \times \left(\frac{42}{12}\right) = 0.70\text{ in} > 0.60\text{ in} \therefore \text{ok} \quad \text{or} \quad 1/2\text{ in} \text{ see Section 2.7}$			

2.6 Test Results (Continued)

Test Specimen 2 of 3

Test Method A			
60 plf x 7 ft - 3-1/2 in = 438 lb Horizontal Concentrated Load on Post At Top Rail Height			
Load Level	Applied Load (lb)	E.T. (min:sec)	Displacement at 42 in Height (in)
0% (0 lb)	0	00:00	-----
50% (219 lb)	220	01:05	-----
25% (110 lb)	110	02:02	0.00
40% (175 lb)	175 – 178	02:23 – 04:29	0.16
55% (241 lb)	241 – 243	04:45 – 06:48	0.34
70% (307 lb)	307 – 309	07:03 – 09:10	0.59
85% (372 lb)	372 – 374	09:29 – 11:53	0.92
100% (438 lb)	438 - 442	12:25 – 14:25	<b>1.42</b>
25% (110 lb)	110	16:12	<b>0.60</b>
<p><u>Deflection Criteria per Section 7.2 of ASTM E 985:</u></p> <p>Maximum Allowable Deflection at Test Load: <math>\frac{h}{12} = \frac{42}{12} = 3.50\text{ in} &gt; 1.42\text{ in} \therefore \text{ok}</math></p> <p>Maximum Allowable Residual Deflection at 25% Load:</p> $20\% \times \left(\frac{h}{12}\right) = 0.2 \times \left(\frac{42}{12}\right) = 0.70\text{ in} > 0.60\text{ in} \therefore \text{ok} \quad \text{or} \quad 1/2\text{ in} \text{ see Section 2.7}$			

## 2.6 Test Results (Continued)

### Test Specimen 3 of 3

Test Method A			
60 plf x 7 ft - 3-1/2 in = 438 lb Horizontal Concentrated Load on Post At Top Rail Height			
Load Level	Applied Load (lb)	E.T. (min:sec)	Displacement at 42 in Height (in)
0% (0 lb)	0	00:00	-----
50% (219 lb)	220	00:28	-----
25% (110 lb)	110	01:17	0.00
40% (175 lb)	175 – 178	01:36 – 03:42	0.17
55% (241 lb)	241 – 243	03:56 – 06:02	0.37
70% (307 lb)	307 – 309	06:23 – 08:31	0.64
85% (372 lb)	372 – 376	08:51 – 10:58	1.00
100% (438 lb)	438 - 441	11:20 – 13:24	<b>1.51</b>
25% (110 lb)	110	14:43	<b>0.68</b>
<u>Deflection Criteria per Section 7.2 of ASTM E 985:</u> Maximum Allowable Deflection at Test Load: $\frac{h}{12} = \frac{42}{12} = 3.50\text{ in} > 1.51\text{ in} \therefore \text{ok}$ Maximum Allowable Residual Deflection at 25% Load: $20\% \times \left(\frac{h}{12}\right) = 0.2 \times \left(\frac{42}{12}\right) = 0.70\text{ in} > 0.68\text{ in} \therefore \text{ok} \quad \text{or} \quad 1/2\text{ in} \text{ see Section 2.7}$			

## 2.7 Summary and Conclusions

The *Solutions* 3-1/2 in square aluminum, flange mounting posts tested and reported herein met the maximum deflection (h/12) and residual deflection (20% x h/12) criteria relative to a 42 in supported railing height and the load criterion for supported rail lengths up to and including 7 ft for all end-use and occupancy classifications of ASTM E 985. They did exceed the 1/2 in residual deflection criterion of ASTM E 985 by 0.10 to 0.18 in. By graphical analysis of the worse case (Specimen 3) load vs deflection curve, the test specimen would have met the maximum residual deflection criterion of 0.5 in for a maximum load of 421 lb, which is equivalent to 60 plf x 7 ft post center to center spacing.

The test results obtained and reported herein are valid indefinitely and do not expire with the end of the service life of this report (see 3.0 Closing Statement).



### 3.0 Closing Statement

This report is reissued in the name of Fairway Building Products, LP through the written authorization of the manufacturer to whom the original report was rendered. The original Report No. is A3925.01-119-19.

Detailed drawings, data sheets, representative samples of test specimens, a copy of this test report, and all other supporting evidence will be retained by Architectural Testing for a period of four years from the original test date. At the end of this retention period, said materials shall be discarded without notice, and the service life of this report by Architectural Testing shall expire. Results obtained are tested values and were secured using the designated test methods. This report neither constitutes certification of this product nor expresses an opinion or endorsement by this laboratory; it is the exclusive property of the client so named herein and relates only to the tested specimens. This report may not be reproduced, except in full, without the written approval of Architectural Testing.

For ARCHITECTURAL TESTING:

---

Adam J. Schrum  
Technician II  
Structural Systems Testing

---

David H. Forney, P.E.  
Senior Project Engineer  
Structural Systems Testing

AJS:ajs/drm

Attachments (pages): This report is complete only when all attachments listed are included.

Appendix A - Drawings (3)

Appendix B - Photographs (1)

### Revision Log

<u>Rev. #</u>	<u>Date</u>	<u>Page(s)</u>	<u>Revision(s)</u>
0	03/15/11	N/A	Original report issue

**APPENDIX A**

**Drawings**

Architectural Testing

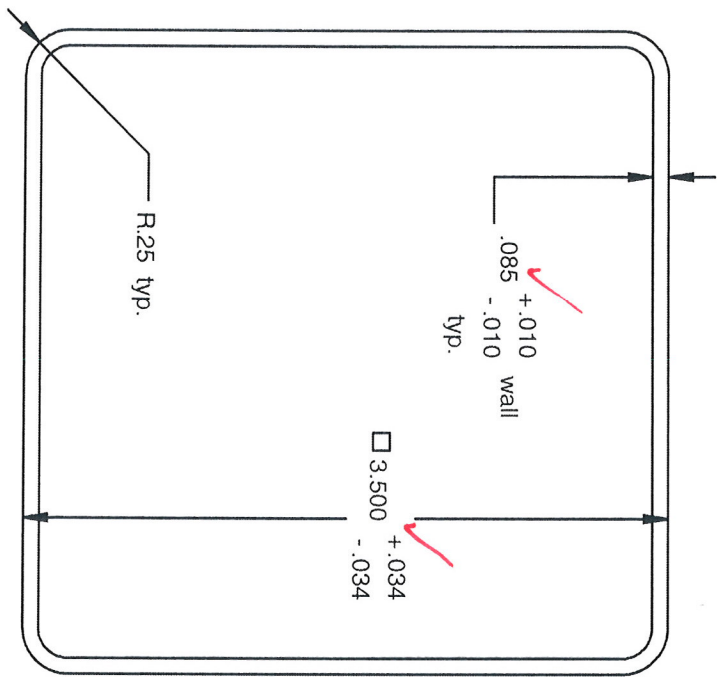

Post

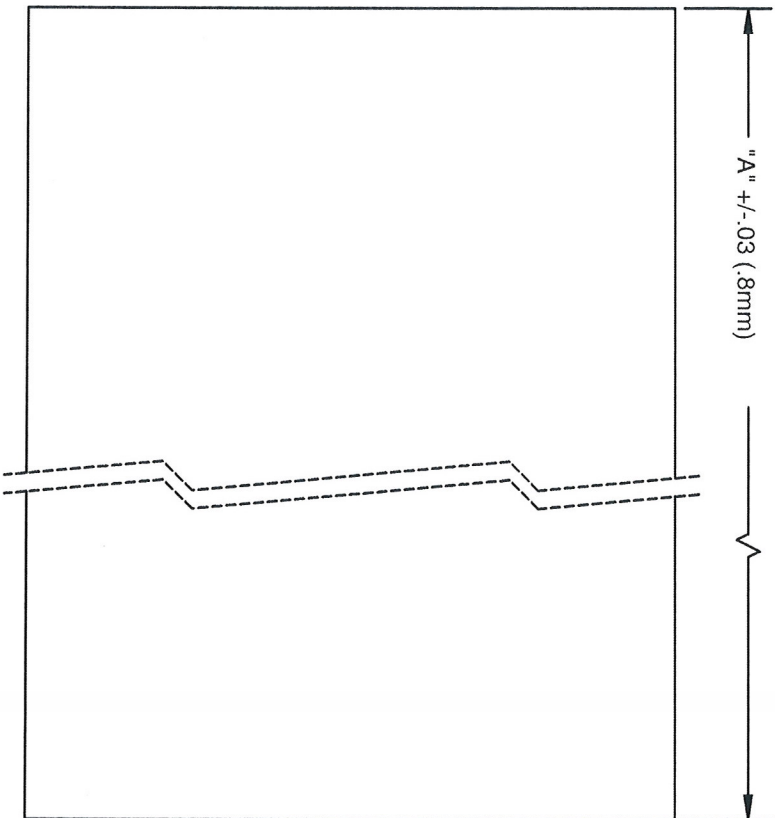

Architectural Testing  
 Test sample conforms with these details.  
 Deviations are noted.  
 Report# A3925.02-119-16  
 Date 3/15/11 Tech ATS

Part #	"A" Length"
PB39	39" (990mm)
PB45	45" (1117mm)
PBS	54" (1371mm)

Fairway Building Products

TITLE:  
Welded Post

DWG. NO.  
Noted

Material  
6063 T5



Base plate  
Side View

$+ .008$   
 $- .008$   
 $0.305$ "

AS

5.44

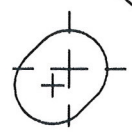

No Hole  
In Product

Architectural Testing  
Test sample compares with these details.  
Deviations are noted.  
Report# A3925-02-119-11  
Date 3/15/11 Tech ATS

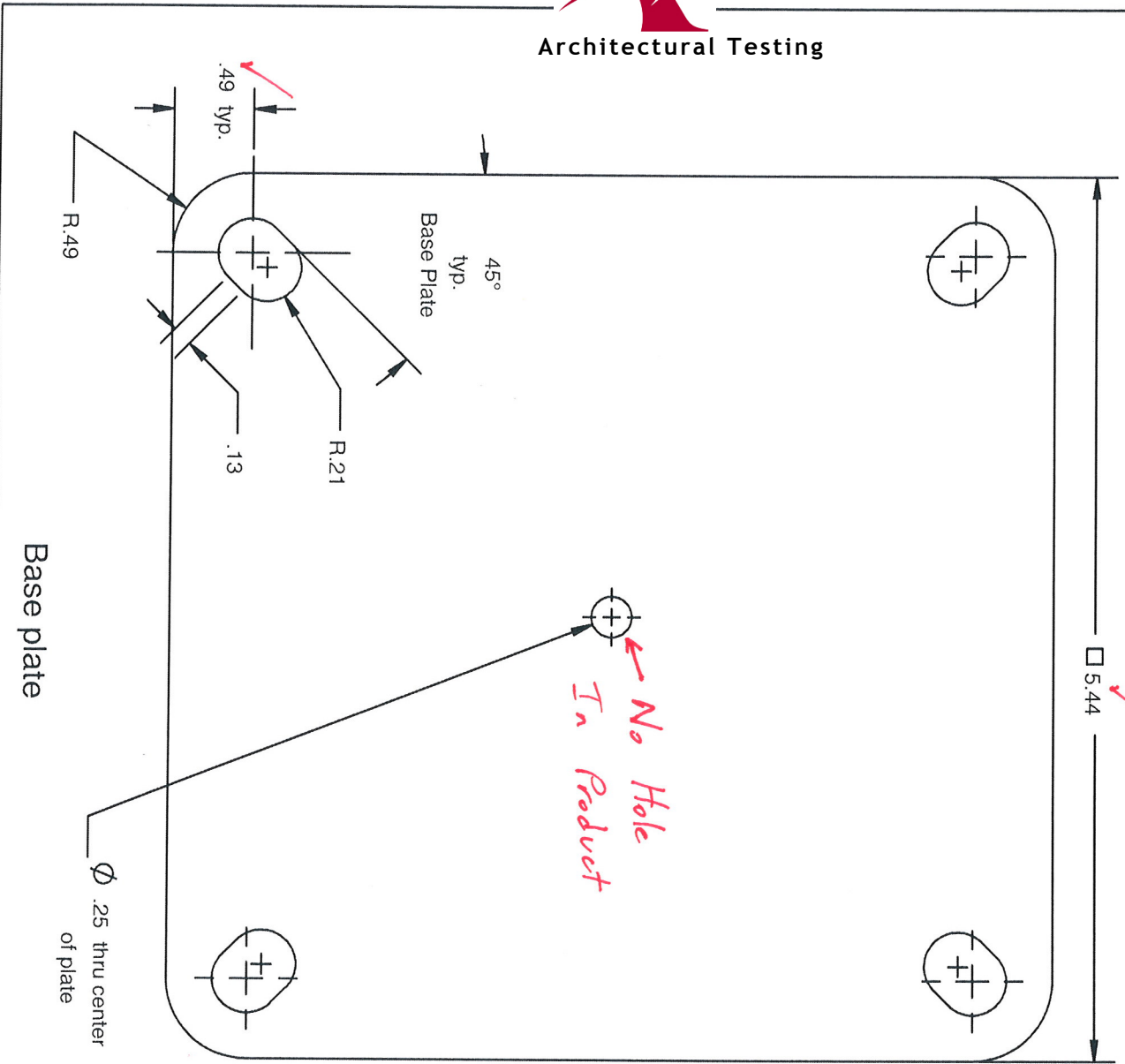

Base plate

$\varnothing .25$  thru center  
of plate

45°  
typ.  
Base Plate

.49  
typ.

R.21  
.13

R.49

TITLE:	
Fairway Building Products	
Welded Post	

DWG. NO.	Noted
Material	6063 T5

Architectural Testing

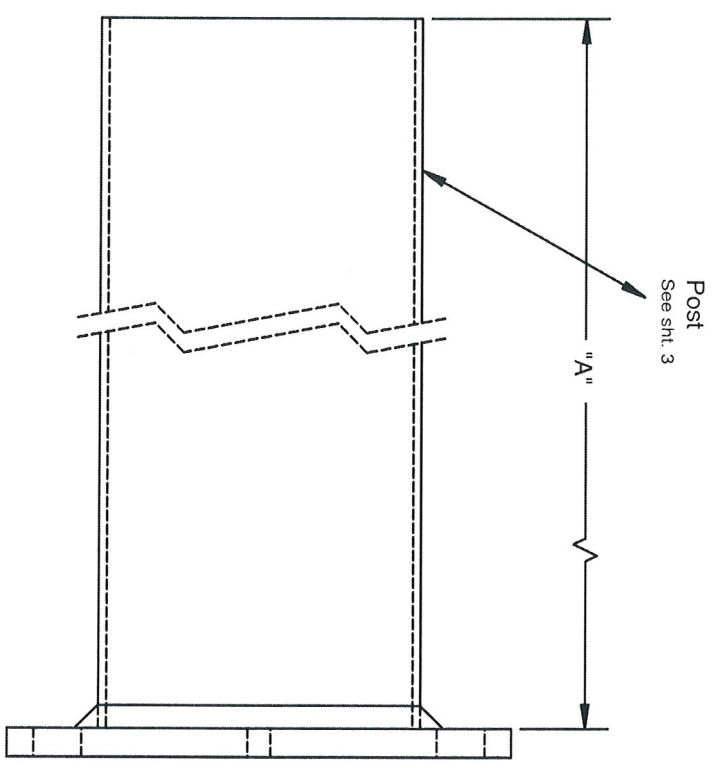
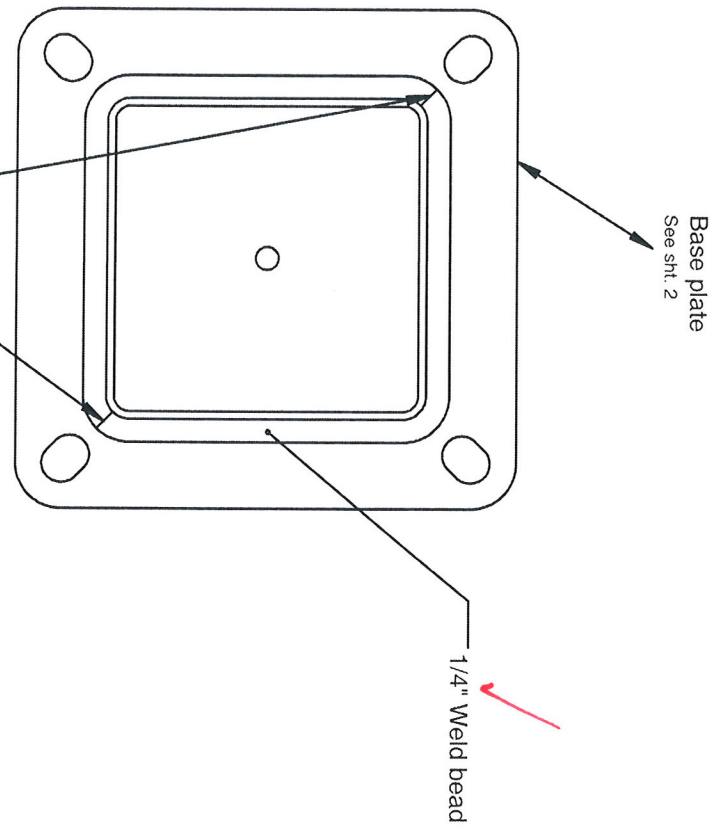

**Architectural Testing**

Test sample complies with these details.  
Deviations are noted.

Report# A3925-02-119-16

Date 3/15/11 Tech ATS

General Table	
Part #	"A"
WP-R	39"
WP-C	45"
WP-S	54"

<b>Fairway Building Products</b>	
TITLE: <b>Welded Post</b>	
DWG. NO. Noted	Material 6063 T5

**APPENDIX B**

**Photographs**



**Photo No. 1**  
**Horizontal Loading of aluminum post, surface-mounted on a steel channel**



**Photo No. 2**  
**Typical base plate deflection under load**