



TEST REPORT

Rendered to:

FAIRWAY BUILDING PRODUCTS, LP

For:

Solutions Aluminum Rail Systems

Report No: 80405.03-119-19
Report Date: 12/01/08

TEST REPORT

80405.03-119-19
December 1, 2008

TABLE OF CONTENTS

1.0 General Information.....	1
1.1 Product.....	1
1.2 Project Description	1
1.3 Limitations.....	1
1.4 Test Witness.....	2
1.5 Product Description	2
2.0 Structural Performance Testing	3
2.1 Scope.....	3
2.2 Test Load and Deflection Criteria	3
2.3 Test Equipment.....	3
2.4 Test Setup	4
2.5 Test Procedure	4
2.6 Test Results.....	5
2.7 Summary and Conclusions	20
3.0 Closing Statement	20
Revision Log.....	21
Appendix A - Drawings	
Appendix B - Photographs	

TEST REPORT

Rendered to:

FAIRWAY BUILDING PRODUCTS, LP
P.O. Box 37
Mount Joy, Pennsylvania 17552

Report No.: 80405.03-119-19
Test Date Started: 09/09/08
Test Date Completed: 09/11/08
Report Date: 12/01/08
Record Retention Date: 09/11/12

1.0 General Information

1.1 Product

Solutions Aluminum Rail Systems

1.2 Project Description

Architectural Testing was contracted by the manufacturer to conduct structural performance tests on 16 ft long by 42 in high *Solutions* aluminum guardrail assemblies, each consisting of two 8 ft guardrail sections and three support posts. This test report is a reissue of the original report 80405.02-119-19. This report is issued in the name of Fairway Building Products, LP through written authorization from the manufacturer. The systems were evaluated in accordance with the following ASTM standards:

ASTM E 935-00, *Standard Test Methods for Performance of Permanent Metal Railing Systems and Rails for Buildings*

ASTM E 985-00, *Standard Specification for Permanent Metal Railing Systems and Rails for Buildings*

1.3 Limitations

All tests performed were to evaluate structural performance of the guardrail assembly to carry and transfer imposed loads to the supporting structure. The test specimens evaluated included the in-fill (balusters), rails, rail brackets and support posts. Anchorage of support posts to the supporting structure was not included in the scope of this testing and would need to be evaluated separately.

1.4 Test Witness

A representative of Fairway Building Products, LP was present to witness all testing reported herein.

1.5 Product Description

Partially-assembled test specimens were supplied by the manufacturer with the following details:

Top Rail: 2 in high by 2-3/4 in wide by 0.08 in wall by 94-3/4 in long contoured (bread loaf) aluminum extrusion

Bottom Rail: 1 in high by 1-1/2 in wide by 0.08 in wall by 94-3/4 in long rectangular aluminum extrusion with rounded corners

Baluster: 3/4 in square by 0.045 in wall by 37 in long aluminum extrusion

Posts:

- 3-1/2 in square by 43-1/2 in long by 0.075 wall aluminum extrusion
- 1-7/8 in square by 39-1/2 in or 48 in long by 0.075 in wall aluminum extrusion

Post Inserts:

- 3 in OD by 1/8 in wall by 8 in long steel tube welded to a 5-1/2 in square by 0.30 in thick base plate with four 7/16 in by 9/16 in oval bolt holes for surface mounting
- 1-1/2 in OD by 3/16 in wall by 23 in long steel tube welded to a 4 in square by 0.30 in thick base plate with four 3/8 in diameter bolt holes 2-7/8 in on-centers for surface mounting
- 1-1/2 in OD by 3/16 in wall by 31 in long steel tube for side / fascia mounting

Post Insert Spacers: 1 in thick aluminum square spacer blocks at the top and bottom of post inserts, each attached to the tube with one 3/16 in roll pin - Post inserts for side / fascia mounting had a third spacer located 5 in above bottom of tube, also attached to the tube with one 3/16 in roll pin

Brackets:

- Top rail to 3-1/2 in post - 3-1/8 in high by 3 in wide by 1-1/2 long aluminum casting with a 2 in by 2-3/4 in contoured (bread loaf) socket and two-hole mounting flange
- Top rail to 1-7/8 in intermediate post - 3 in wide by 4-7/8 in long by 3-1/4 high aluminum casting with a 2 in by 2-3/4 in contoured (bread loaf) through-socket and 1.71 in square by 1 in long male fitting for insertion into the top of a 1-7/8 in square intermediate post
- Bottom rail to post - 2.1 in high by 1.7 in wide by 1.5 in long aluminum casting with a 1.04 in high by 1.47 in wide socket and two-hole mounting flange

Bottom Rail Support: 3/4 in square by 0.045 in wall by appropriate length aluminum extrusion at mid-span of each bottom rail

1.5 Product Description (Continued)

Fasteners:

- Top rail bracket to 3-1/2 in post - two #8 x 3/4 in pan head self-tapping stainless steel sheet metal screws through bracket holes into post
- Top rail bracket to 1-7/8 in intermediate post - one #8 x 3/4 in pan head self-tapping stainless steel sheet metal screw through post hole into bracket
- Top rail brackets to top rail - one #8 x 3/4 in pan head self-tapping stainless steel sheet metal screw through bracket hole into bottom of rail
- Bottom rail bracket to post - two #8 x 3/4 in pan head self-tapping stainless steel sheet metal screws through bracket holes into post

See drawings in Appendix A and photographs in Appendix B for additional details.

2.0 Structural Performance Testing

2.1 Scope

Three specimens, each consisting of two guardrail sections and three posts, were tested according to the four test methods described in ASTM E 935 in a laboratory set to maintain temperature in the range of $68 \pm 4^{\circ}\text{F}$ and humidity in the range of $50 \pm 5\% \text{ RH}$.

2.2 Test Load and Deflection Criteria

The test load criteria for rail and post members were 365 lb concentrated load and 60 plf uniformly distributed load to address the worse case end-use category loading defined in ASTM E 985, Section 7.1. The test load criterion for in-fill members was 50 lb as defined in ASTM E 985, Section 7.1 for all end-use categories. The deflection criteria for top rail and posts were as defined in ASTM E 985, Section 7.2.

2.3 Test Equipment

The guardrail assemblies were tested on a self-contained rigid steel test fixture designed to accommodate anchorage of the rail assembly and application of the required test loads. The specimens were loaded using an electric winch mounted to a rigid steel test frame. High strength steel cables, load distribution plates and spreader beams were used to impose test loads on the specimens. Applied load was measured using an electronic load cell located in-line with the loading system. Electronic linear displacement transducers were used to measure deflections. Deflections and load values were electronically recorded continuously throughout the loading process. The cone used for Test Method D was HDPE, 1 in diameter tapered to 5 in diameter with an overall length of 15 in and rested on a PTFE plate.

2.4 Test Setup

Each test specimen was inspected prior to testing to verify size and general condition of the materials, assembly and installation. No potentially compromising defects were observed prior to testing. Each specimen was a 16 ft wide by 42 in high level guardrail assembly consisting of two 8 ft guardrail sections, one intermediate rail-over post and two end posts. Anchorage of posts to concrete was simulated by bolting them to rigid steel test fixtures with 5/16 in hex head steel cap screws with flat washers. Post anchorage and fasteners were not within the scope of testing. Transducers mounted to independent reference frames were located to record guardrail system deflection at the point(s) of loading. See photographs in Appendix B for individual test setups.

2.5 Test Procedure

Test procedures were conducted according to the referenced standards and are further defined below.

2.5.1. Test Methods A, B and C

Method A - *Application of Horizontal Static Load to Top Rail*

Method B - *Application of Vertical Static Load to Top Rail*

Method C - *Application of Horizontal Static Load to In-fill Areas of Baluster and Panel Railing Systems*

- A preload of 50% of test load was applied and then released
- A load of 25% of test load was applied and deflection readings were zeroed
- Load was increased to 40% of test load and maintained for at least 2 minutes
- Load was increased to 55% of test load and maintained for at least 2 minutes
- Load was increased to 70% of test load and maintained for at least 2 minutes
- Load was increased to 85% of test load and maintained for at least 2 minutes
- Load was increased to the full test load and maintained for at least 2 minutes
- Load was decreased to 25% of test load and deflections recorded
- Deflections were also recorded at the conclusion of each 2 minute hold period

2.5.2. Test Method D

Method D - *Application of a Horizontal Static Load to Determine Resistance to Cone Penetration by In-fill Area of Baluster and Panel Railing Systems*

- Load was gradually increased to the full test load and then released

2.5.3. Test Sequence

Test Specimen 1

- Method B - Vertical uniform load on both top rails, simulated by quarter point loading
- Method A - Horizontal concentrated load on top rail adjacent to 3-1/2 in surface mount end post
- Method A - Horizontal concentrated load on top rail adjacent to 1-7/8 in surface mount end post
- Method C - Horizontal concentrated load on one square foot area at mid-height of two balusters
- Method D - Horizontal load on cone at mid-height between two balusters
- Method B - Two vertical concentrated loads on top rails adjacent to 1-7/8 in side / fascia-mount intermediate post
- Method A - Horizontal concentrated load on top rail adjacent to 1-7/8 in side / fascia-mount post with one guardrail section removed to create an end-post condition

Note that Method A testing was applied adjacent to an end post per ASTM E 935, Section 13.1.

Note that all three posts were tested by Method A as end posts.

Test Specimens 2 and 3

- Method B - Two vertical concentrated loads on top rails adjacent to 1-7/8 in side / fascia-mount intermediate post
- Method B - Vertical uniform load on both top rails, simulated by quarter point loading
- Method A - Two horizontal concentrated loads at mid-span of both top rails
- Method C - Horizontal concentrated load on one square foot area at mid-height of two balusters
- Method D - Horizontal load on cone at mid-height between two balusters

Note that for Specimen 2, Method A testing was applied to both top rails at mid-span per ASTM E 935, Section 13.1.

Note for Specimen 3, Method A testing is to be a repeat of the "weaker" of Specimen 1 or 2 per ASTM E 935, Section 13.1; which was determined by deflection results to be Specimen 2.

2.6 Test Results

The following tests were performed on the test specimens in accordance with the test load requirements of the referenced standards.

Key to Test Results Tables:

Load Level: Target test load expressed as percent of test load criterion and (lb)

Applied Load: Actual applied load - Where more than one value is reported, the applied load was the range (min. - max.) that was held during the time indicated for the test

Elapsed Time (E.T.): The length of time into the test with zero established at the beginning of the loading procedure - Where more than one value is reported, the time was the range (start-end) that the applied load was maintained

Displacement: Total specimen displacement measured at or adjacent to point of load unless noted otherwise

2.6 Test Results (Continued)

Test Specimen 1 of 3

Test Method A 365 lb Horizontal Concentrated Load on Top Rail Adjacent to 3-1/2 in Surface Mount End Post Test Date: 09/09/08			
Load Level ¹	Applied Load (lb)	E.T. (min:sec)	Displacement (in)
0% (0 lb)	0	00:00	-----
50% (435 lb)	438	01:26	-----
25% (217 lb)	218	02:22	0.00
40% (348 lb)	347 - 349	05:19 - 07:30	0.13
55% (478 lb)	474 - 482	12:29 - 14:31	0.29
70% (608 lb)	605 - 609	18:46 - 20:51	0.47
85% (739 lb)	736 - 742	26:57 - 29:21	0.68
100% (869 lb)	862 - 871	36:31 - 039:31	0.91
25% (217 lb)	217	41:03	0.10
<u>Deflection Criteria per Section 7.2 of ASTM E 985:</u> Maximum Allowable Deflection at Test Load: $\frac{h}{12} = \frac{42}{12} = 3.50 > 0.91 \therefore ok$ Maximum Allowable Residual Deflection at 25% Load: $20\% \times \left(\frac{h}{12}\right) = 0.2 \times \left(\frac{42}{12}\right) = 0.70 > 0.10 \therefore ok$ or $1/2 \text{ in} > 0.10 \therefore ok.$			

¹ A pivoted spreader beam was used to apply load to rail. Load was applied to spreader beam 63 in from fulcrum and spreader beam applied load to rail 150 in from fulcrum. $(150 / 63) \times 365 \text{ lb test load} = 869 \text{ lb applied load}$

2.6 Test Results (Continued)

Test Method A 365 lb Horizontal Concentrated Load on Top Rail Adjacent to 1-7/8 in Surface Mount End Post Test Date: 09/10/08			
Load Level ¹	Applied Load (lb)	E.T. (min:sec)	Displacement (in)
0% (0 lb)	0	00:00	-----
50% (432 lb)	437	01:01	-----
25% (216 lb)	217	01:42	0.00
40% (345 lb)	343 - 347	10:05 - 12:10	0.26
55% (475 lb)	453 - 476	18:02 - 21:05	0.57
70% (604 lb)	600 - 607	27:24 - 29:47	0.91
85% (734 lb)	730 - 736	40:06 - 42:12	1.26
100% (863 lb)	856 - 867	49:19 - 51:30	1.63
25% (216 lb)	216	53:05	0.19
<u>Deflection Criteria per Section 7.2 of ASTM E 985:</u> Maximum Allowable Deflection at Test Load: $\frac{h}{12} = \frac{42}{12} = 3.50 > 1.63 \therefore ok$ Maximum Allowable Residual Deflection at 25% Load: $20\% \times \left(\frac{h}{12}\right) = 0.2 \times \left(\frac{42}{12}\right) = 0.70 > 0.19 \therefore ok$ or $1/2 \text{ in} > 0.19 \therefore ok.$			

¹ A pivoted spreader beam was used to apply load to rail. Load was applied to spreader beam 63-1/4 in from fulcrum and spreader beam applied load to rail 149-1/2 in from fulcrum. $(149-1/2 / 63-1/4) \times 365 \text{ lb test load} = 863 \text{ lb applied load}$

2.6 Test Results (Continued)

Test Method A 365 lb Horizontal Concentrated Load on Top Rail ¹ Adjacent to 1-7/8 in Side / Fascia Mount Post Test Date: 09/10/08			
Load Level	Applied Load (lb)	E.T. (min:sec)	Displacement (in)
0% (0 lb)	0	00:00	-----
50% (183 lb)	184	01:21	-----
25% (91 lb)	92	02:00	0.00
40% (146 lb)	145 - 146	03:28 - 05:33	0.26
55% (201 lb)	199 - 202	09:18 - 11:28	0.56
70% (256 lb)	254 - 256	13:27 - 15:38	0.88
85% (310 lb)	308 - 316	18:05 - 21:28	1.21
100% (365 lb)	363 - 367	24:28 - :27:25	1.55
25% (91 lb)	91	28:23	0.15
<u>Deflection Criteria per Section 7.2 of ASTM E 985:</u> Maximum Allowable Deflection at Test Load: $\frac{h}{12} = \frac{42}{12} = 3.50 > 1.55 \therefore ok$ Maximum Allowable Residual Deflection at 25% Load: $20\% \times \left(\frac{h}{12}\right) = 0.2 \times \left(\frac{42}{12}\right) = 0.70 > 0.15 \therefore ok$ or $1/2 \text{ in} > 0.15 \therefore ok.$			

¹ One guardrail section was removed from the post to create a worse case end post condition and test load was applied to the remaining top rail

2.6 Test Results (Continued)

Test Method B¹ 960 lb Vertical Uniform Load² on Both Top Rails Simulated by Quarter Point Loading³ Test Date: 09/09/08		
Load Level	Applied Load (lb)	E.T. (min:sec)
0% (0 lb)	0	00:00
50% (480 lb)	481	01:37
25% (240 lb)	241	03:27
40% (384lb)	383 - 389	05:39 - 07:42
55% (528 lb)	524 - 530	10:34 - 12:43
70% (672 lb)	668 - 675	19:16 - 22:00
85% (816 lb)	807 - 824	23:30 - 25:33
100% (960 lb)	949 - 966	26:36 - 28:46
25% (240 lb)	240	32:15

¹ There is no deflection criterion for Test Method B when loading with a uniform load

² Test load = 60 plf x 16 ft = 960 lb, which is worse case than the prescribed 365 lb concentrated load on each rail

³ Quarter point loading was used as a worse case due to the bottom rail center support blocks

2.6 Test Results (Continued)

Test Method B¹ Two 240 lb Vertical Concentrated Loads² on Top Rails Adjacent to 1-7/8 in Side / Fascia Mount Intermediate Post Test Date: 09/09/08		
Load Level	Applied Load (lb)	E.T. (min:sec)
0% (0 lb)	0	00:00
50% (240 lb)	245	00:50
25% (120 lb)	121	01:27
40% (192 lb)	191 - 201	01:57 - 03:47
55% (264 lb)	252 - 270	04:05 - 07:00
70% (336 lb)	323 - 348	08:14 - 10:20
85% (408 lb)	390 - 414	10:42 - 13:05
100% (480 lb)	322 - 505	13:36 - 15:32
25% (120 lb)	120	16:01

¹ There is no deflection criterion for Test Method B when loading adjacent to a post

² The test load represents the tributary portion of a 60 plf load carried by the intermediate post (60 plf x 8 ft = 480 lb) which is worse case than the prescribed 365 lb concentrated load

2.6 Test Results (Continued)

Test Method C¹ Two 50 lb Horizontal Concentrated Loads, Each on One Square Foot Area at Mid-Height of Two Balusters Test Date: 09/10/08		
Load Level	Applied Load (lb) ²	E.T. (min:sec)
0% (0 lb)	0	00:00
50% (50 lb)	50	01:13
25% (25 lb)	25	02:03
40% (40 lb)	39 - 42	02:17 - 04:29
55% (55 lb)	53 - 59	04:36 - 06:36
70% (70 lb)	66 - 72	06:46 - 09:16
85% (85 lb)	82 - 87	09:25 - 11:31
100% (100 lb)	96 - 104	11:40 - 14:07
25% (25 lb)	25	14:30

¹ There is no deflection criterion for Test Method C

² A spreader beam was used to apply 50 lb load to 1 sq ft at the middle of the in-fill of both rail sections simultaneously; hence, applied load was doubled

Test Method D 50 lb Horizontal Load on Cone at Mid-Height Between Two Balusters Test Date: 09/10/08			
Load Level	Applied Load (lb)	E.T. (min:sec)	Observations
0% (0 lb)	0	00:00	-
100% (50 lb)	48 - 56	00:26 - 00:34	Cone did not penetrate fully and applied load did not decrease.

2.6 Test Results (Continued)

Test Specimen 2 of 3

Test Method A				
365 lb Horizontal Concentrated Load at Mid-Span of Both Top Rails				
Test Date: 09/10/08				
Load Level	Applied Load ¹ (lb)	E.T. (min:sec)	Displacement (in)	
			A Rail ²	B Rail ³
0% (0 lb)	0	00:00	-----	-----
50% (365 lb)	374	01:07	-----	-----
25% (183 lb)	183	02:03	0.00	0.00
40% (292 lb)	291 - 294	07:04 - 09:31	0.32	0.40
55% (402 lb)	398 - 410	11:55 - 15:23	0.69	0.85
70% (511 lb)	509 - 514	18:46 - 20:57	1.07	1.28
85% (621 lb)	619 - 625	24:33 - 26:56	1.46	1.73
100% (730 lb)	727 - 735	25:59 - 32:50	1.86	2.21
25% (183 lb)	183	33:54	0.11	0.10
<u>Deflection Criteria per Section 7.2 of ASTM E 985:</u> Maximum Allowable Deflection at Test Load: $\frac{h}{12} + \frac{l}{96} = \frac{42}{12} + \frac{96}{96} = 4.50 > 2.21 \therefore ok$ Maximum Allowable Residual Deflection at 25% Load: $20\% \times \left(\frac{h}{12} + \frac{l}{96} \right) = 0.2 \times 4.50 = 0.90 > 0.11 \therefore ok$ or $1/2 \text{ in} > 0.11 \therefore ok$.				

¹ A spreader beam was used to apply 365 lb load to both rail sections simultaneously; hence, applied load was doubled

² Rail A was between 3-1/2 in end post and 1-7/8 in intermediate post

³ Rail B was between 1-7/8 in end post and 1-7/8 in intermediate post

2.6 Test Results (Continued)

Test Method B¹ 960 lb Vertical Uniform Load² on Both Top Rails Simulated by Quarter Point Loading³ Test Date: 09/10/08		
Load Level	Applied Load (lb)	E.T. (min:sec)
0% (0 lb)	0	00:00
50% (480 lb)	489	01:35
25% (240 lb)	241	02:57
40% (384lb)	382 - 387	03:41 - 05:44
55% (528 lb)	516 - 533	06:05 - 08:33
70% (672 lb)	662 - 678	09:11 - 11:19
85% (816 lb)	806 - 822	12:11 - 14:13
100% (960 lb)	952 - 970	15:28 - 17:40
25% (240 lb)	240	19:31

¹ There is no deflection criterion for Test Method B when loading with a uniform load

² Test load = 60 plf x 16 ft = 960 lb, which is worse case than the prescribed 365 lb concentrated load on each rail

³ Quarter point loading was used as a worse case due to the bottom rail center support blocks

2.6 Test Results (Continued)

Test Method B¹ Two 240 lb Vertical Concentrated Loads² on Top Rails Adjacent to 1-7/8 in Side / Fascia Mount Intermediate Post Test Date: 09/09/08		
Load Level	Applied Load (lb)	E.T. (min:sec)
0% (0 lb)	0	00:00:00
50% (240 lb)	240	00:01:27
25% (120 lb)	120	00:02:25
40% (192 lb)	190 - 197	00:02:44 - 00:04:49
55% (264 lb)	247 - 268	00:05:00 - 00:07:06
70% (336 lb)	323 - 342	00:07:19 - 00:09:22
85% (408 lb)	323 - 430	00:09:35 - 00:11:38
100% (480 lb)	470 - 486	00:11:53 - 00:13:49
25% (120 lb)	120	00:15:04

¹ There is no deflection criterion for Test Method B when loading adjacent to a post

² The test load represents the tributary portion of a 60 plf load carried by the intermediate post (60 plf x 8 ft = 480 lb) which is worse case than the prescribed 365 lb concentrated load

2.6 Test Results (Continued)

Test Method C ¹ Two 50 lb Horizontal Concentrated Loads, Each on One Square Foot Area at Mid-height of Two Balusters Test Date: 09/11/08		
Load Level	Applied Load (lb) ²	E.T. (min:sec)
0% (0 lb)	0	00:00
50% (50 lb)	50	00:47
25% (25 lb)	25	01:20
40% (40 lb)	38 - 42	02:07 - 04:12
55% (55 lb)	51 - 57	04:22 - 06:32
70% (70 lb)	68 - 73	06:51 - 08:56
85% (85 lb)	84 - 87	09:20 - 11:34
100% (100 lb)	98 - 102	12:01 - 14:27
25% (25 lb)	25	14:52

¹ There is no deflection criterion for Test Method C

² A spreader beam was used to apply 50 lb load to 1 sq ft at the middle of the in-fill of both rail sections simultaneously; hence, applied load was doubled

Test Method D 50 lb Horizontal Load on Cone at Mid-height Between Two Balusters Test Date: 09/11/08			
Load Level	Applied Load (lb)	E.T. (min:sec)	Observations
0% (0 lb)	0	00:00	-
100% (50 lb)	48 - 55	00:28 - 00:52	Cone did not penetrate fully and applied load did not decrease.

2.6 Test Results (Continued)

Test Specimen 3 of 3

Test Method A				
365 lb Horizontal Concentrated Load at Mid-span of Both Top Rails				
Test Date: 09/11/08				
Load Level	Applied Load ¹ (lb)	E.T. (min:sec)	Displacement (in)	
			A Rail ²	B Rail ³
0% (0 lb)	0	00:00	-----	-----
50% (365 lb)	366	02:01	-----	-----
25% (183 lb)	184	02:49	0.00	0.00
40% (292 lb)	290 - 294	05:23 - 07:40	0.34	0.42
55% (402 lb)	400 - 407	10:24 - 12:34	0.74	0.91
70% (511 lb)	507 - 513	15:06- 18:05	1.14	1.38
85% (621 lb)	619 - 642	19:15 - 23:40	1.58	1.88
100% (730 lb)	725 - 737	27:41 - 31:50	2.01	2.35
25% (183 lb)	183	34:03	0.19	0.13
<u>Deflection Criteria per Section 7.2 of ASTM E 985:</u>				
Maximum Allowable Deflection at Test Load: $\frac{h}{12} + \frac{l}{96} = \frac{42}{12} + \frac{96}{96} = 4.50 > 2.35 \therefore ok$				
Maximum Allowable Residual Deflection at 25% Load:				
$20\% \times \left(\frac{h}{12} + \frac{l}{96} \right) = 0.2 \times 4.50 = 0.90 > 0.19 \therefore ok$ or $1/2 \text{ in} > 0.19 \therefore ok.$				

¹ A spreader beam was used to apply 365 lb load to both rail sections simultaneously; hence, applied load was doubled

² A Rail was between 3-1/2 in end post and 1-7/8 in intermediate post

³ B Rail was between 1-7/8 in end post and 1-7/8 in intermediate post

2.6 Test Results (Continued)

Test Method B¹ 960 lb Vertical Uniform Load² on Both Top Rails Simulated by Quarter Point Loading³ Test Date: 09/11/08		
Load Level	Applied Load (lb)	E.T. (min:sec)
0% (0 lb)	0	00:00
50% (480 lb)	484	01:10
25% (240 lb)	240	02:03
40% (384lb)	383 - 389	02:55 - 05:11
55% (528 lb)	511 - 532	06:31 - 08:44
70% (672 lb)	668 - 679	10:49 - 13:05
85% (816 lb)	802 - 826	14:15 - 16:16
100% (960 lb)	954 - 975	17:37 - 19:32
25% (240 lb)	240	21:11

¹ *There is no deflection criterion for Test Method B when loading with a uniform load*

² *Test load = 60 plf x 16 ft = 960 lb, which is worse case than the prescribed 365 lb concentrated load on each rail*

³ *Quarter point loading was used as a worse case due to the bottom rail center support blocks*

2.6 Test Results (Continued)

Test Method B¹ Two 240 lb Vertical Concentrated Loads² on Top Rails Adjacent to 1-7/8 in Side / Fascia Mount Intermediate Post Test Date: 09/11/08		
Load Level	Applied Load (lb)	E.T. (min:sec)
0% (0 lb)	0	00:00
50% (240 lb)	241	00:47
25% (120 lb)	120	02:19
40% (192 lb)	190 - 194	03:22 - 05:30
55% (264 lb)	253 - 270	05:48 - 08:10
70% (336 lb)	326 - 360	:09:29 - 11:36
85% (408 lb)	405 - 422	12:06 - 13:55
100% (480 lb)	470 - 492	15:08 - 17:42
25% (120 lb)	120	19:04

¹ *There is no deflection criterion for Test Method B when loading adjacent to a post*

² *The test load represents the tributary portion of a 60 plf load carried by the intermediate post (60 plf x 8 ft = 480 lb) which is worse case than the prescribed 365 lb concentrated load*

2.6 Test Results (Continued)

Test Method C¹ Two 50 lb Horizontal Concentrated Loads Each on One Square Foot Area at Mid-Height of Two Balusters Test Date: 09/11/08		
Load Level	Applied Load (lb)²	E.T. (min:sec)
0% (0 lb)	0	00:00
50% (50 lb)	50	00:36
25% (25 lb)	25	02:20
40% (40 lb)	40 - 43	03:28 - 06:02
55% (55 lb)	53 - 60	06:19 - 09:08
70% (70 lb)	68 - 71	09:39 - 11:11
85% (85 lb)	81 - 89	11:41 - 4:14
100% (100 lb)	99 - 109	14:33 - 17:47
25% (25 lb)	25	18:51

¹ There is no deflection criterion for Test Method C

² A spreader beam was used to apply 50 lb load to 1 sq ft at the middle of the in-fill of both rail sections simultaneously; hence, applied load was doubled

Test Method D 50 lb Horizontal Load on Cone at Mid-Height Between Two Balusters Test Date: 09/11/08		
Load Level	Applied Load (lb)	E.T. (min:sec)
0% (0 lb)	0	00:00
100% (50 lb)	49 - 52	00:35 - 00:36

2.7 Summary and Conclusions

The 8 ft by 42 in level *Solutions* Aluminum Rail Systems tested and reported herein met all of the load and deflection criteria of the referenced standards with support post conditions as specified in the table below.

Post Size	Post Mount	Post Condition
3-1/2 in square	Surface Mount	End
1-7/8 in square	Surface Mount	End or Intermediate (rail-over)
1-7/8 in square	Side / Fascia Mount	End or Intermediate (rail-over)

The test results obtained and reported herein are valid indefinitely and do not expire with the end of the service life of this report (see 3.0 Closing Statement).

3.0 Closing Statement

This report is issued in the name of Fairway Building Products, LP through written authorization from the manufacturer to whom the report was originally rendered. The original report number is 80405.02-119-19.

Detailed drawings, data sheets, representative samples of test specimens, a copy of this test report, and all other supporting evidence will be retained by Architectural Testing for a period of four years from the original test date. At the end of this retention period, said materials shall be discarded without notice, and the service life of this report by Architectural Testing shall expire. Results obtained are tested values and were secured using the designated test methods. This report neither constitutes certification of this product nor expresses an opinion or endorsement by this laboratory; it is the exclusive property of the client so named herein and relates only to the tested specimens. This report may not be reproduced, except in full, without the written approval of Architectural Testing.

For ARCHITECTURAL TESTING:

Keith A. Gurnee
Technician II
Structural Systems Testing

David H. Forney, P.E.
Senior Project Engineer
Structural Systems Testing

KAG:dhf/alb

Attachments (pages): This report is complete only when all attachments listed are included.

Appendix A - Drawings (8)

Appendix B - Photographs (4)

Revision Log

<u>Rev. #</u>	<u>Date</u>	<u>Page(s)</u>	<u>Revision(s)</u>
0	12/01/08	N/A	Original report issue

APPENDIX A

Drawings

Solutions Square Aluminum Balusters

#6063-T5 Aluminum Alloy

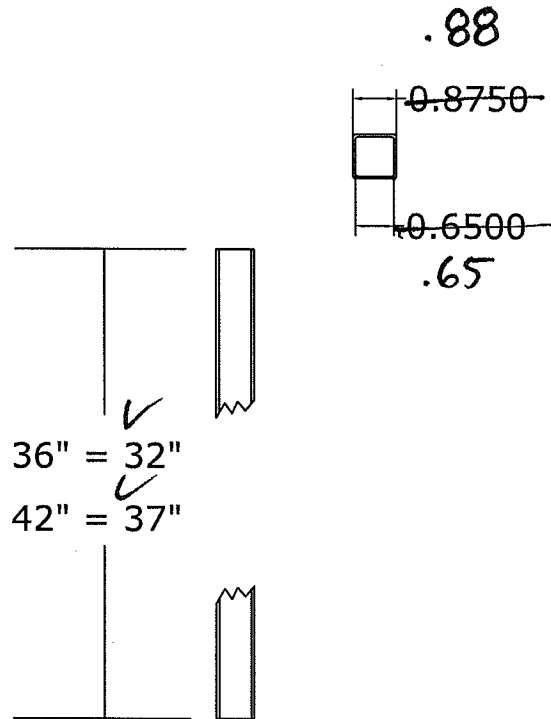

Baluster Plugs

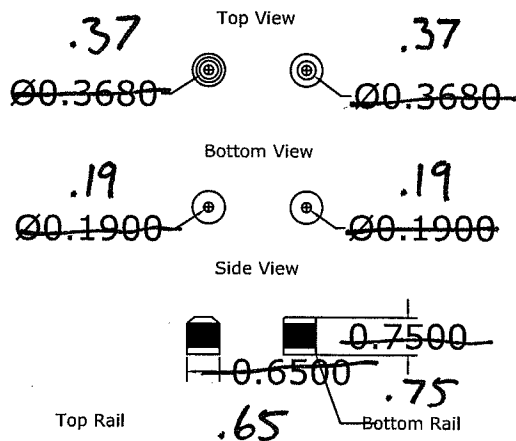

Test sample complies with these details.
Deviations are noted.

Report# 80405.02-119-19
Date 10-03-08 Tech KAG

Solutions Structural Mounting Post

#A512 Steel Alloy

3.5" x 3.5" Structural Post

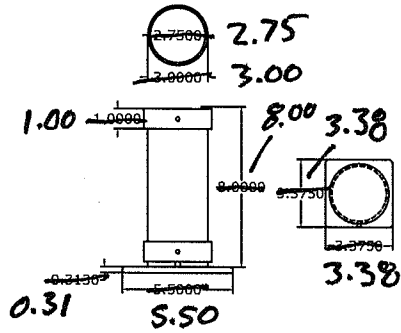

Architectural Testing

Test sample complies with these details.
Deviations are noted.

Report# 80405.02-119-19

Date 10-03-08 Tech KAG

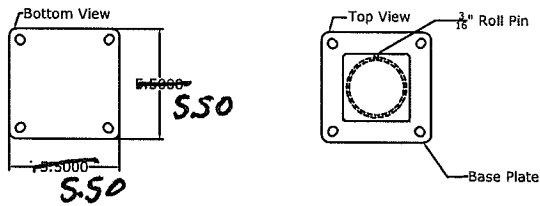

~~1.875 x 1.875~~ Structural Post

1.88 x 1.88

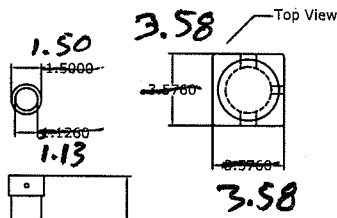

~~1.875 x 1.875~~ Side Mount Structural Post

1.88 x 1.88

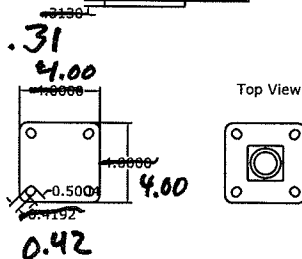
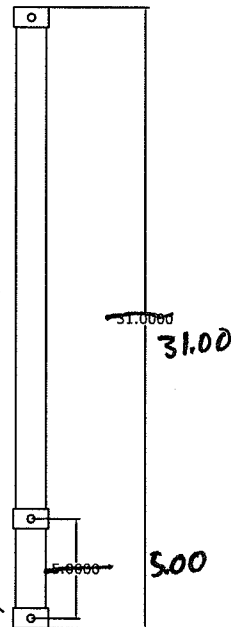
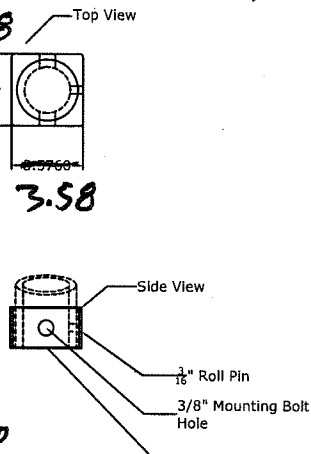

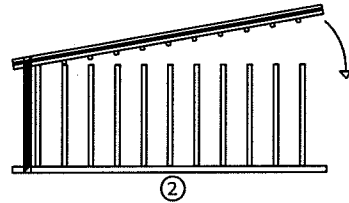
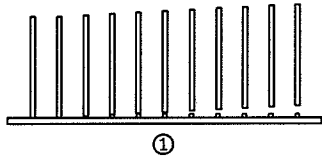

OR

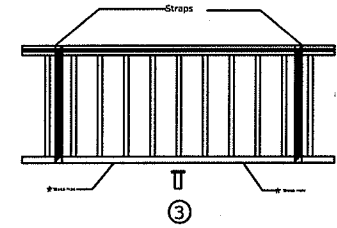
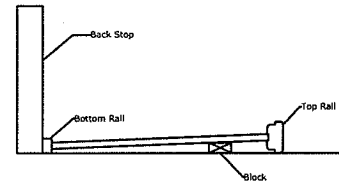

STEP #4

NOTE: Always lay Rail components on a non-abrasive surface. This is a pre finish product & damage to the finish may occur.

- 1 . Insert Balusters onto Bottom rail over baluster Plugs.
- 2 . Insert first two Balusters from one end onto Top rail & strap. Finish inserting balance of Balusters into Top rail & strap.

OR

Insert Balusters onto Bottom rail. Lay rail section on a flat surface & block Balusters up to match insert plugs on Top rail & insert balusters. Install straps on both ends.

- 3 . Install Foot Block at center section of railing (may need trimmed to correct height). Drill one $\frac{3}{16}$ " holes at mid points between end of rail and Foot Block on both sides.

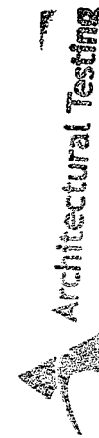

Architectural Testing

Test sample complies with these details.
Deviations are noted.

Report# 80405.02 -119-19

Date 10-03-08

Tech KAG

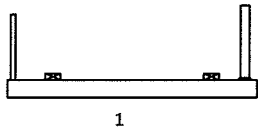

1

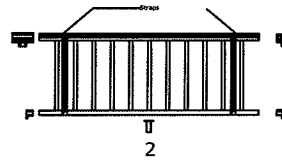

2

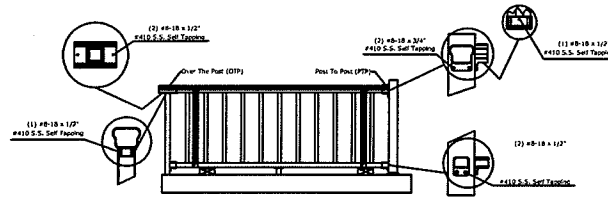

3 & 4

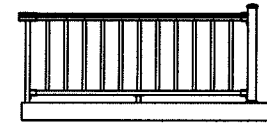

5

STEP #5

- 1 . Cut two "Spacer Blocks" 2" in height & place 12" in from post.
- 2 . Slide both Top & Bottom mounting brackets on ends of rail section
- 3 . Set rail section between post & center mounting bracket on post.
- 4 . Install proper screws in mounting brackets (see #4 drawing).
- 5 . Remove strapes & Spacer Blocks. Install Post Caps & Base Trim.

Architectural Testing
 Test sample complies with these details.
 Deviations are noted.
 Report# 80405.02-119-19
 Date 10-03-08 Tech KAG

Solution Aluminum Guardrail Test Sample

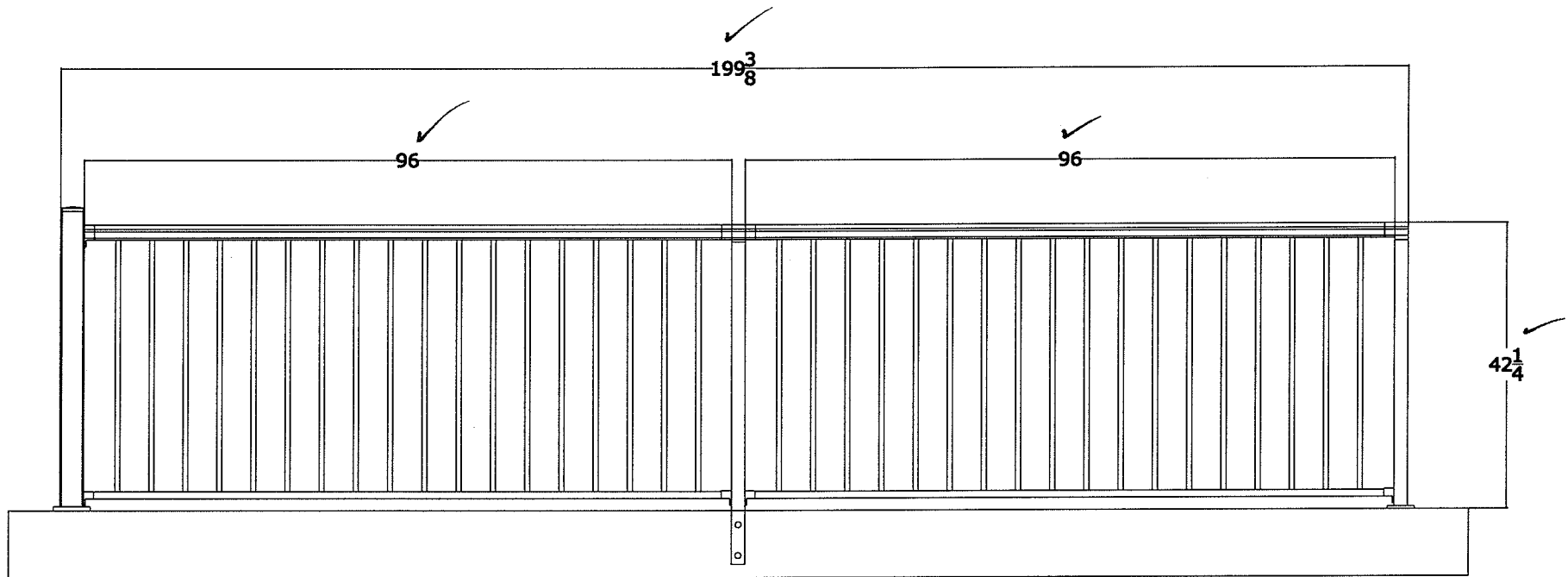

Architectural Testing

Test sample complies with these details.
Deviations are noted.

Report# 80405.02-119-19

Date 10-29-08 Tech DHF

Solutions Mounting Brackets

Top & Bottom Rails

ADC 12 Castings

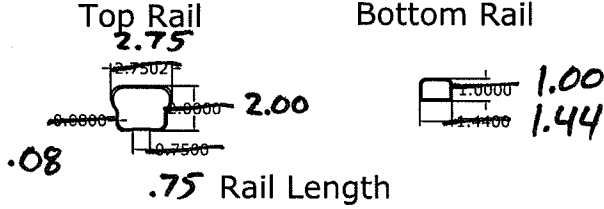

Mounting Brackets

Top Railing Bracket (PTP)

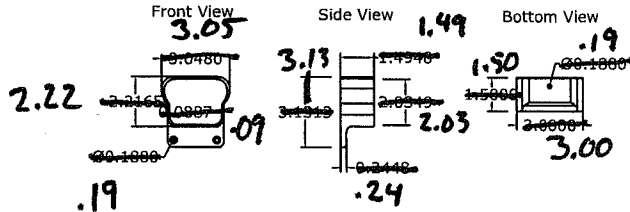

Top Railing Bracket (OTP)

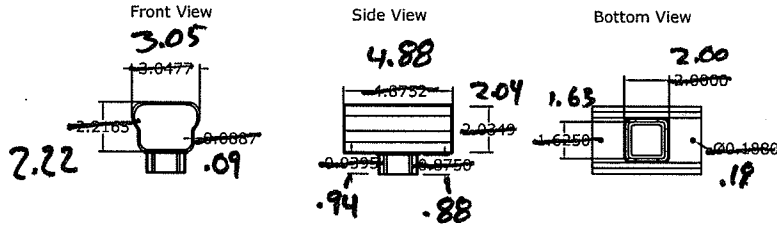

Bottom Railing Bracket (PTP)

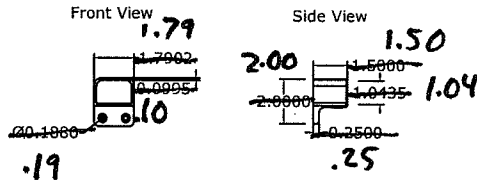

Mounting Screws

#710 Stainless Steel - Self Tapping

Top Mounting Bracket

Post to Post & Over the Post - 3 ea. #8 x 3/4"

Bottom Bracket

Post to Post & Over the Post - 2 ea. #8 x 1/2"

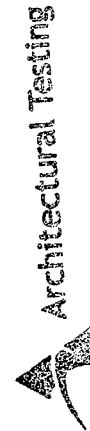

Test sample complies with these details.
 Deviations are noted.

Report# 80405.02-119-19

Date 11-03-08 Tech KAG

Solutions Aluminum Post Sleeve

#A512 Steel Alloy

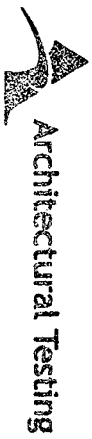
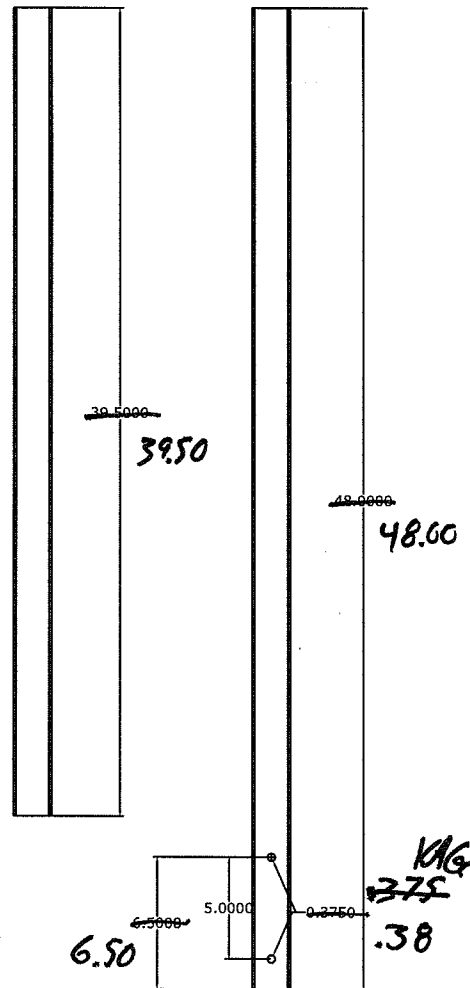
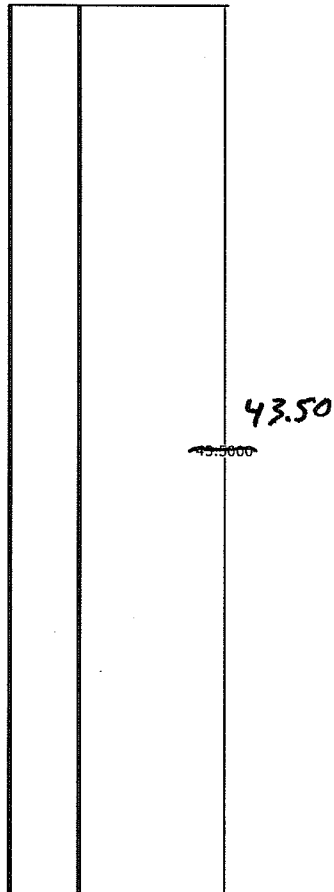
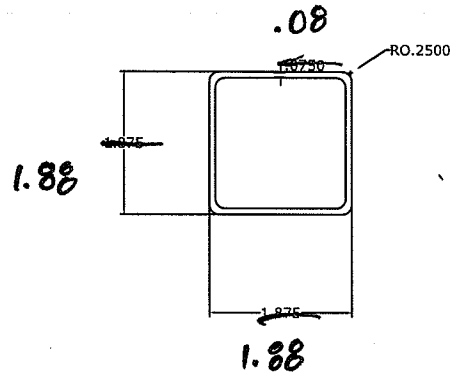
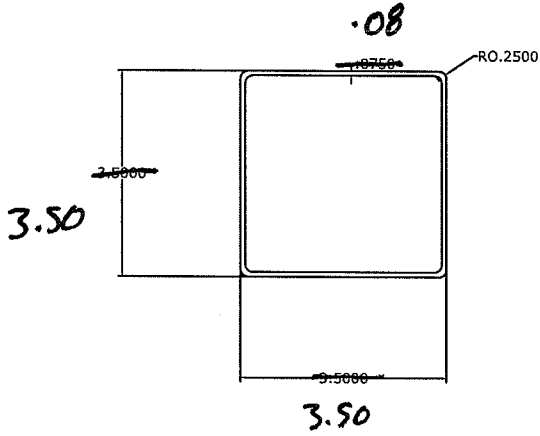

Test sample complies with these details.
Deviations are noted.

Report# 80405.02-119-19
Date 10-03-08 Tech KAG

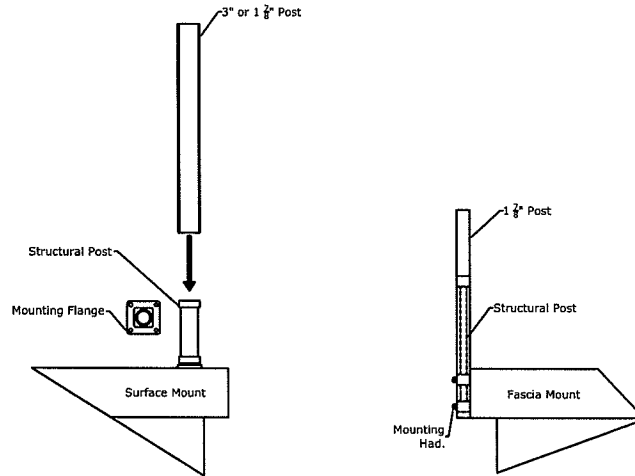
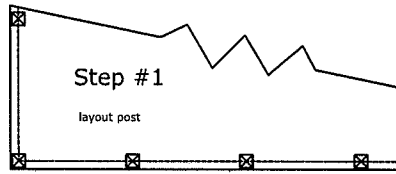

Step #2

With post layout completed, determined size & post mount required (3 1/2"x 3 1/2" Post to Post or 1 7/8"x 1 7/8" Over the Post), (3 1/2"x 3 1/2" Surface Mount or 1 7/8"x 1 7/8" Surface or Fascia Mount).

SURFACE MOUNT:

1. Set Structural Post in place & mark four (4) mounting holes. Drill for 5/16" mounting bolts (Hardware Not Supplied)
2. Set Structural Post in place & install mounting bolts. Check Structural Post with level & shim if necessary (use metal or composite shims)
3. Slide Post Cover over Structural Post & adjust height if necessary.

FASCIA MOUNT:

1. Insert Structural Post inside 1 7/8" Post Sleeve. Align pre drilled holes in Structural Post with bottom of 1 7/8" Sleeve Post.
NOTE: 1 7/8" Post layout is, 8" end to mount on Fascia - 2" gap between finish deck & bottom of bottom rail & balance of post for 36" & 42" height railing.
2. Set Post in place & mark & drill for 5/16" mounting bolts (Hardware Not Supplied).
3. Set post in place & install mounting hardware. Check post with level & shim if necessary (use metal shims)

Architectural Testing
Test sample complies with these details.
Deviations are noted.
Report# BO40502-119-19
Date 10-03-08 Tech KAG

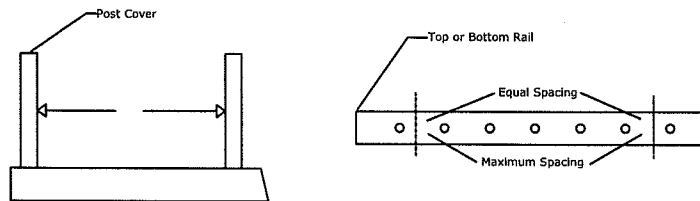

Step #3

With Post set and plumb, measure distance between Post Covers where rail brackets attach.

1. Measure distance from post cover to post cover and deduct 1/4".
2. Measure Bottom Rail making sure there is Maximum & Even spacing from end of rail to first baluster on both ends of bottom rail.
3. Cut rail with a metal cutting blade (Check Manufacturer's specs for proper blade). Always lay pre finish material on a clean non surface when cutting or assembling.
4. Repeat above steps to cut Top Rail (make certain balusters spacing match Top & Bottom rail).

APPENDIX B

Photographs



Photo No. 1
Test Method A - Specimen One
Horizontal Concentrated Load on Top Rail Adjacent to 3-1/2 in Surface Mount Post



Photo No. 2
Test Method A - Specimen One
Horizontal Concentrated Load on Top Rail Adjacent to 1-7/8 in Surface Mount Post



Photo No. 3
Test Method A - Specimen One
Horizontal Concentrated Load on Top Rail Adjacent to 1-7/8 in Surface Mount Post
with Right Guardrail Section Removed to Create an End Post Condition



Photo No. 4
Test Method B - Typical for Specimens Two and Three
Vertical Uniform Load Simulated by Quarter Point Loading of Both Top Rails



Photo No. 5
Test Method B - Typical for Specimens Two and Three
Vertical Concentrated Load on Top Rails Adjacent to 1 7/8 in Side / Fascia Mount Post



Photo No. 6
Test Method C - Typical for all Specimens
Horizontal Concentrated Load on In-Fill at Mid-Height of Two Balusters



Photo No. 7
Test Method D - Typical for all Specimens
Horizontal Load on Cone at Mid-Height of Two Balusters